

## Single-chip AC Direct Step Drive Solution intelligent Highly Integrated SSL System Solution

**Altoran ACS1004** is a single-chip AC direct step drive power solution for Solid State Lighting (SSL) systems. Using Altoran's *patented direct step drive technology*, the ACS1004 enables SSL system designers the ability to design LED systems driven directly from AC mains with the best cost/performance metrics in the industry. Using only two small external components, the technology enables the lowest cost, highest performance, smallest footprint and lowest BOM count, most integrated AC Direct Drive Solution available. Altoran employs *intelligence* and *integration* to provide high efficiency drive of LED light sources resulting in the industry's highest performance *AC mains-to-light* solution. The high degree of integration increases reliability, lowers cost, reduces solution size, number of discrete components, and system complexity. The elimination of transformer and electrolytic capacitors further increases system reliability. The ACS1004 is designed in such a manner that it does not degrade or distort the AC waveform, as seen by the AC mains, providing near unity Power Factor (PF) and extremely low total harmonic distortion (THD). This eliminates the need for additional components to correct for PF, THD, and EMI commonly found in conventional drive architectures. Intelligence is designed into the ACS1004 to enable the widest input voltage range - resulting in low input voltage sensitivity - external control features required in the SSL market, as well as the widest range of dimming capability w/o added cost. The combination of these technology advances provides the user with an elegant yet powerful arsenal of capabilities not available in the market today and provides a full *AC-mains to light* solution.

### Altoran ACS1004 AC Direct Step Drive Solution

- Highly integrated *AC mains-to-light solution* in a single Silicon IC
- Lowest solution cost, ~\$0.10/W
- Up to 97% solution efficiency
- Near unity Power Factor, 0.99
- Extremely low THD, < 15%
- No electrolytic capacitors or Transformer
- Low Flicker drive of LED sources

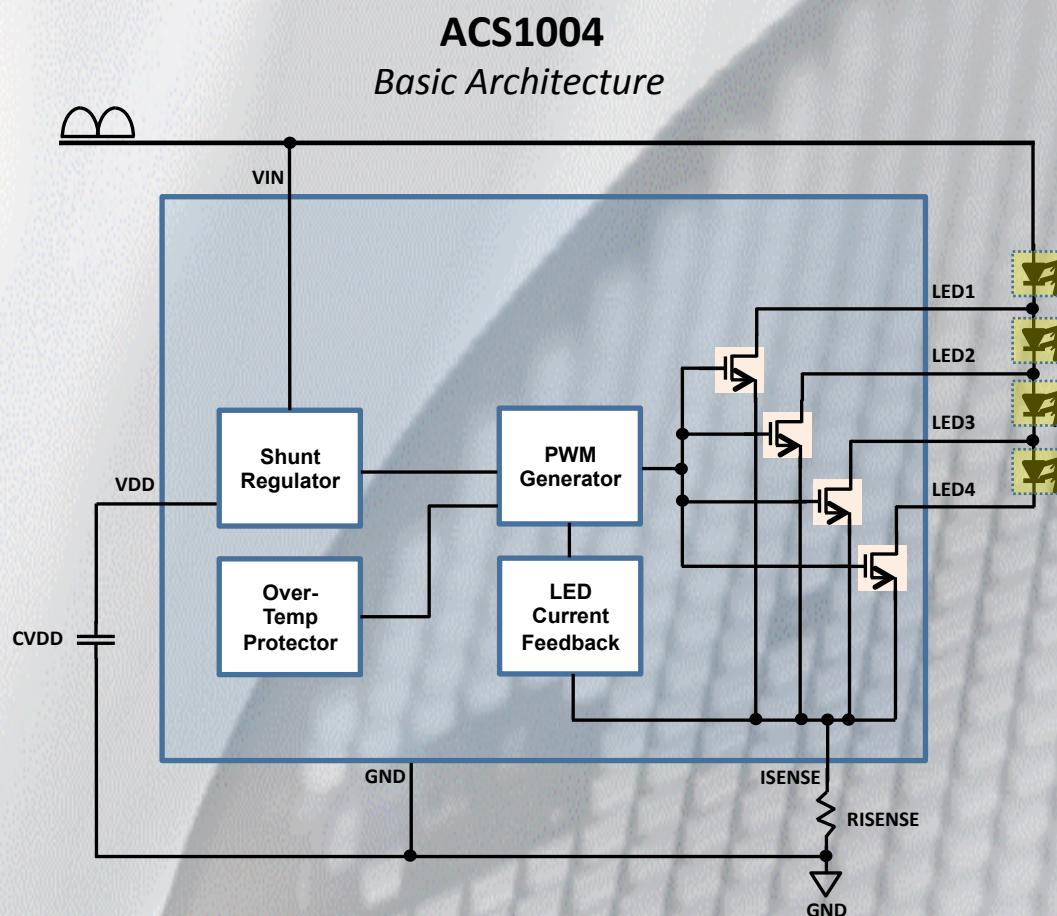

### Altoran ACS1004 AC Direct Step Drive Solution

FEATURES	BENEFITS
Highest level of <i>intelligence and integration</i>	<i>Lowest cost, highest performance, smallest footprint, AC mains-to-light solution available</i> Increased reliability – no electrolytic caps or transformers Increased functionality (dimming and smart controls)
Wide input voltage range (90-280VAC)	One IC to address U.S. and all international line voltages: US 115/277VAC, International 230VAC
Efficiency up to 97%	Increased system efficacy/Lower cost of light
Non-isolated design	Direct drive from AC mains – no transformer Smaller, lower cost, higher performance
Distortion-less AC operation	Near unity PF, Extremely low THD No need for PFC or THD reducing components No need for EMI filtering
Superior dim ability and dimmer compatibility	Works with Triac and 0-10V dimmers Smooth monotonic dimming from 100% to 0%
Optional Valley-Fill configuration	Reduced flicker illumination
Over Current/Over Temperature Protection	Protects SSL system from catastrophic damage

### ACS1004 General Specifications

Parameter	Unit	Value
AC Mains	VAC RMS	90 - 280
I <sub>F</sub> (max)	mA	75
Power, max <sup>(1)</sup>	W	9 @ 120VAC / 17 @ 220 VAC
Efficiency	%	97
PFC		0.99
THD	%	< 15
T <sub>J</sub> (max)	C	150

Notes:

1. IC's can be linked to enable higher power designs.